



CT24VX24- Black
CT24VX25- Brown
• Opel Insignia 2009 ->
• Vauxhall Insignia 2009->

Double DIN Kit contents

- (1) Facia Plate
- (2) Mounting Bracket Left
- (3) Mounting Bracket Right
- (4) Fixing screws
- (5) Fixing clips



11. Mount air condition control unit to double DIN facia place
Mount small speaker to double DIN facia plate



12. Remove switch for ESP (left) and switch for Park Distance Control (right). Put them to the openings at the top of double DIN facia plate.



13. Fix mounting brackets to double DIN navigation.

Connect all required circuit points and mount double DIN head unit to dash board. Place facia plate. Re-install everything in reverse order to finish installation

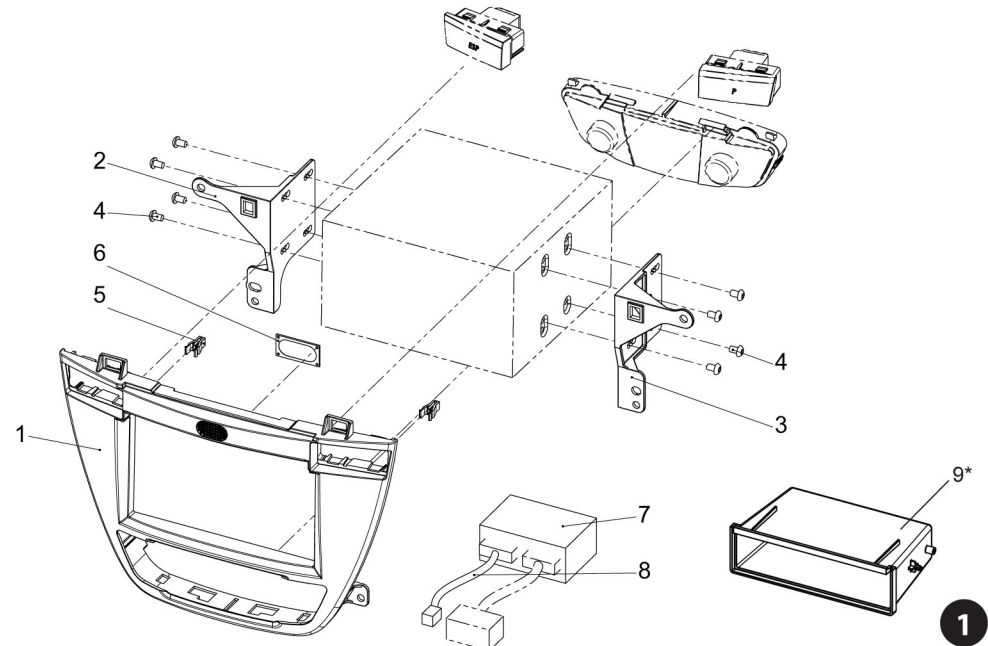



1. Insignia OEM dash board



2. Unclip cover of cigarette lighter

Remove cigarette lighter unit

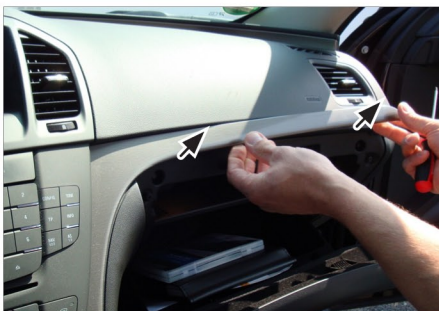

3. Unclip side panel (left) and remove it



4. Unclip side panel (right) and remove it

Steering wheel control interface menu set up



The Interface has various functions so here is a list of them all:

- Press Wheel IN/SRC - Enter Menu & Select once in Menu & SOURCE in Radio operation.
- VOL +/VOL - Works just the same
- Wheel UP/DOWN - navigate menu up/down & seek up/down in Radio operation
- HANG-UP/MUTE - Back in menu & Mute in Radio operation



This is the first screen of the menu, you can make any selection you wish from here.



Now if you press DOWN on the wheel the highlighted item will change to the one below.



LOGO SELECT on the menu is the one that is required.



Press **IN** on the SRC/WHEEL to go into the **LOGO SELECT** settings.



Now you can scroll **UP/DOWN** on the SRC/WHEEL to select the required setting you want to appear on the display.



Once you have selected the option you require then to go back to the main menu you press **PHONE HANG-UP/MUTE**, this will return you to the previous menu.

The same actions are applied to whatever menu you wish to change.

Steering wheel control interface install guide

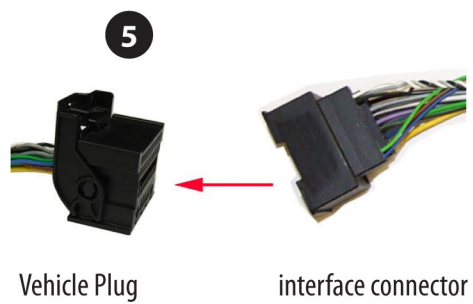
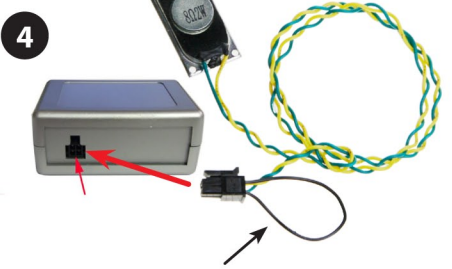
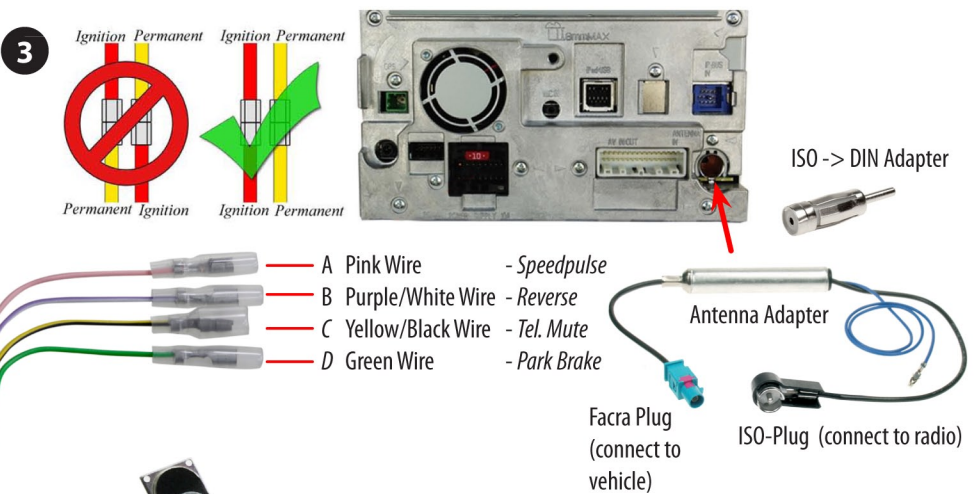
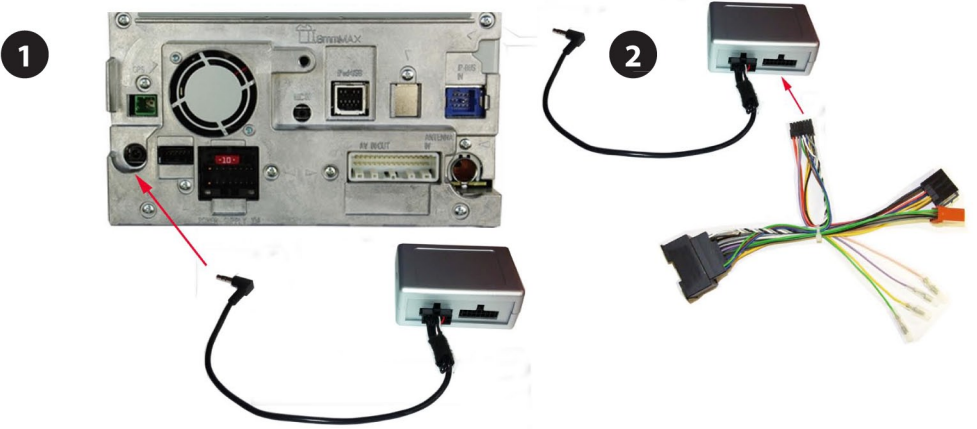

A - vehicles with 4 line dash display only:
Cut and insulate this (black) loop
 B - Connect speaker to slot in facia plate



5. Unclip and remove OEM display



6. Unclip and remove OEM head unit
 Remove OEM CD/Radio unit



7. Remove OEM cd/radio parts



8. Remove air condition control unit from OEM panel

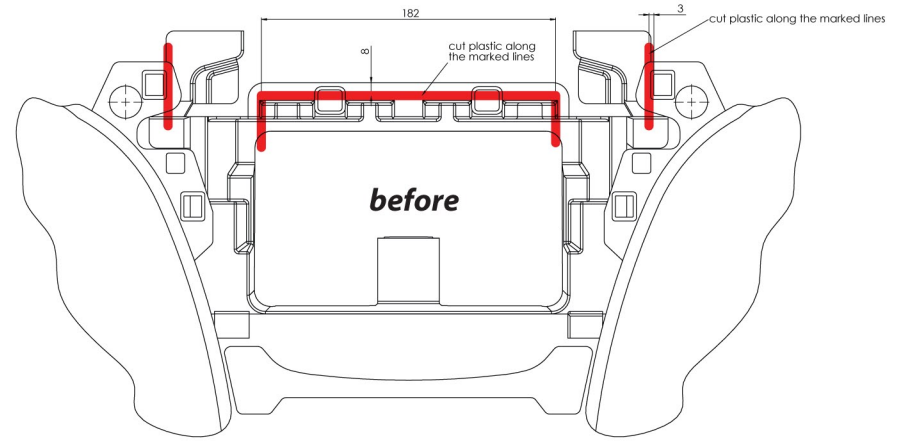
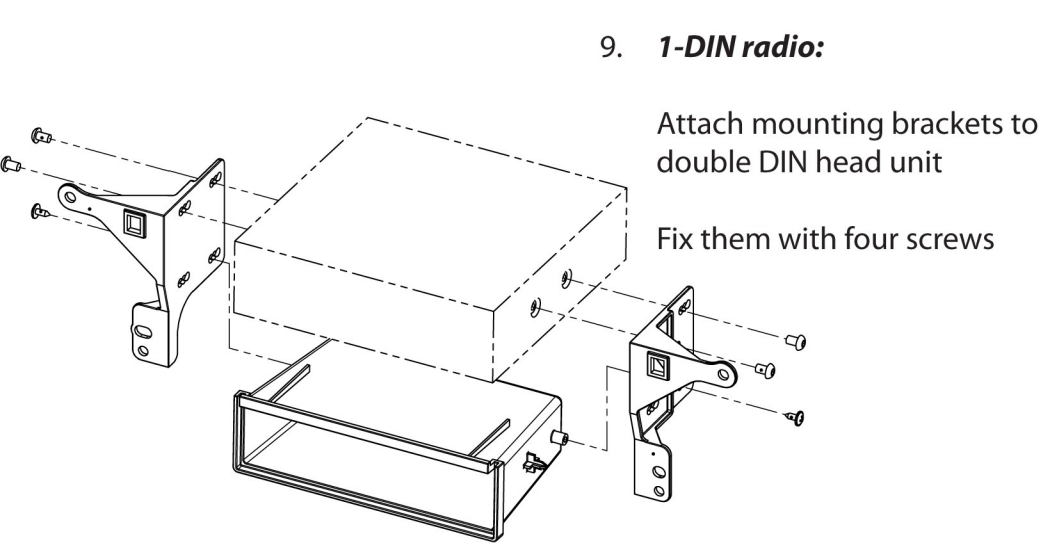

10. Cut plastic from dash board in order to clear space for the double DIN head unit (see lines in the drawing)

